

These are general guidelines only; more information may be required on a case-by-case basis

When is a building permit required for a deck?

- If the deck is **not attached** to a dwelling and is larger than 15m² or 161ft²
- Decks attached to structures where any surface is greater than 24" above grade
- If structural renovations will be made to an existing deck

Required Documents for Building Permit Application

- Fully completed application preferably via CloudPermit at ca.cloudpermit.com, or a fully completed hardcopy application form completed at the Municipal Office
- Completed [Schedule 1: Designer Information](#) form for the individual taking design responsibility for the project
- **1 set** of **electronic** construction drawings (PDF only)
- Comprehensive site plan

All documents to be submitted electronically in PDF format

Site Plan Requirements

A comprehensive site plan or copy of the property survey showing:

- Dimensions of property and proposed location of deck
- Location of well and septic system and setback distances to both features, if applicable
- Distances from proposed structure to property lines

Construction Drawings Requirements

Depending on the nature of the proposed construction and other variables, plans may be required to have a designer stamp, BCIN, Architect and/or Engineer (as applicable). The construction drawings must show:

- Plan view including:**
 - i. Footing detail (Helical Piles must be stamped by a professional engineer)
 - ii. Joist/beam sizing, spans and direction
 - iii. Stairs and landings
 - iv. Connection to existing structure (if attached)
 - v. Roof construction (truss layout and direction (**if deck/porch is covered**))
- Elevation views** (front and side)
 - i. Height of deck and guard above grade to be noted
- Sections**
 - i. Cross Section
 - ii. Wall sections (as needed)

Guards/Railings (for decks 24” or higher)

The Ontario Building Code permits the installation of wood guards/railings. Should you plan on installing anything other than a wood guard/railing, please submit a copy of the Pre-Engineered guard/railing details with your building permit application. Typically, you can receive this package of details from the supplier.

Any CCMC approved material is acceptable.

(Note: Hollow plastic or vinyl guards or railings are not permitted)

Building Permit Fees

Please refer to the Township of Mapleton’s [Fees & Charges By-law](#) in effect at the time of application for current rates. Applicable fees are payable upon collection of the Building Permit and cover all plans review, building permit, and resulting inspections.

Need Assistance?

Reach out for assistance any time at building@mapleton.ca or 519-638-3313 X029.

Application forms, schedules, and other documents are available on the Building Department webpage under [Building Permit Guides and Documents](#) - Additional Application Forms and Schedules.

Note: Once a Building Permit application has been submitted, questions can be asked directly to Building Department staff through the permit workspace within Cloudpermit.

RESIDENTIAL DECK DESIGN GUIDE

The attached deck design guide is intended to streamline the design and approval process for the installation of a new residential deck. The information and details within the guide have been vetted by Building Officials and Tacoma Engineers Inc. to ensure compliance with the Ontario Building Code.

The first three pages of the guide are sample deck layouts; pick the one that best fits your project and fill in all required information on the layout page. The remaining pages within the guide are listed below, these will provide you with the information and details needed to complete the above task. These details are intended to give you options based on your project type/design and construction comfort level. Make sure you check off the details you will be utilizing and provide the information as requested. The entire package will be submitted to the Building Department as part of your application for a permit to construct a deck.

If you have any questions, please do not hesitate to contact your local building department.

Deck Design Guide Pages

Page 1a:	Layout 1: Single Beam Option	select your layout and provide all required information
Page 1b:	Layout 2: Double Beam Option	
Page 1c:	Layout 3: Single Beam Option – End Beam at House	

Note: Your layout can be modified to suite your design; please indicate the proposed location of stairs on the layout as well

Page 2: Deck Beam, Joist and Footing Tables
Table A: Deck Joists spans
Table B: Deck Beams spans
Table C: Footing Sizing

Page 3: Deck Section – **provide deck height**

Page 4&4a: Footing and pier options – **indicate the detail you will be using**

Page 5&5a: Beam Connections – **indicate the detail you will be using**

Page 6&7: Ledger Board/End Beam Connections – **indicate the detail you will be using**

Page 8: Deck Section – Guardrail detail – **provide all information**

Page 9&10: Guardrail Options – if an alternative guardrail is proposed, approvals for the guardrail will be required to be submitted with the permit application. The required information should be available through the dealer.

Page 11: Stair Section

* Lateral bracing may be required if deck is greater than 1:1 ratio (width vs length) or at the discretion of the local building department*

If you are proposing to construct a deck that does not utilize the details within the guide, an engineer may be required to review your proposed design and provide their seal and signature to ensure the proposed design meets requirements of the Ontario Building Code; this will be at the discretion of your local building department.

The scope of this deck design guide is limited to the following:

Individual/single dwelling units; single storey in height. Only uniformly distributed loading cases have been considered within the scope of this deck guide. Additional design and review by a Professional Engineer may be required in consideration of any additional superimposed, composite or concentrated loads that may be imposed upon the designed deck structure. A deck structure designed under this guide is not commensurate with an external balcony as described by OBC Div. B, Table 4.1.5.3.

Hot tubs/spas are NOT permitted.



DECK LAYOUT 1: SINGLE BEAM OPTION

SCALE: 1/4" = 1'-0"

DECK BOARD MATERIAL

(Check one)

- PRESSURE TREATED
- CEDAR

DECK BOARD SIZE

(Check one)

- 5/4" DECK BOARDS (deck joists must be at 16" o/c max)
- 2"x6" DECK BOARDS
- OTHER _____

DECK BEAM/JOIST MATERIAL

(Check one)

- PRESSURE TREATED
- CEDAR

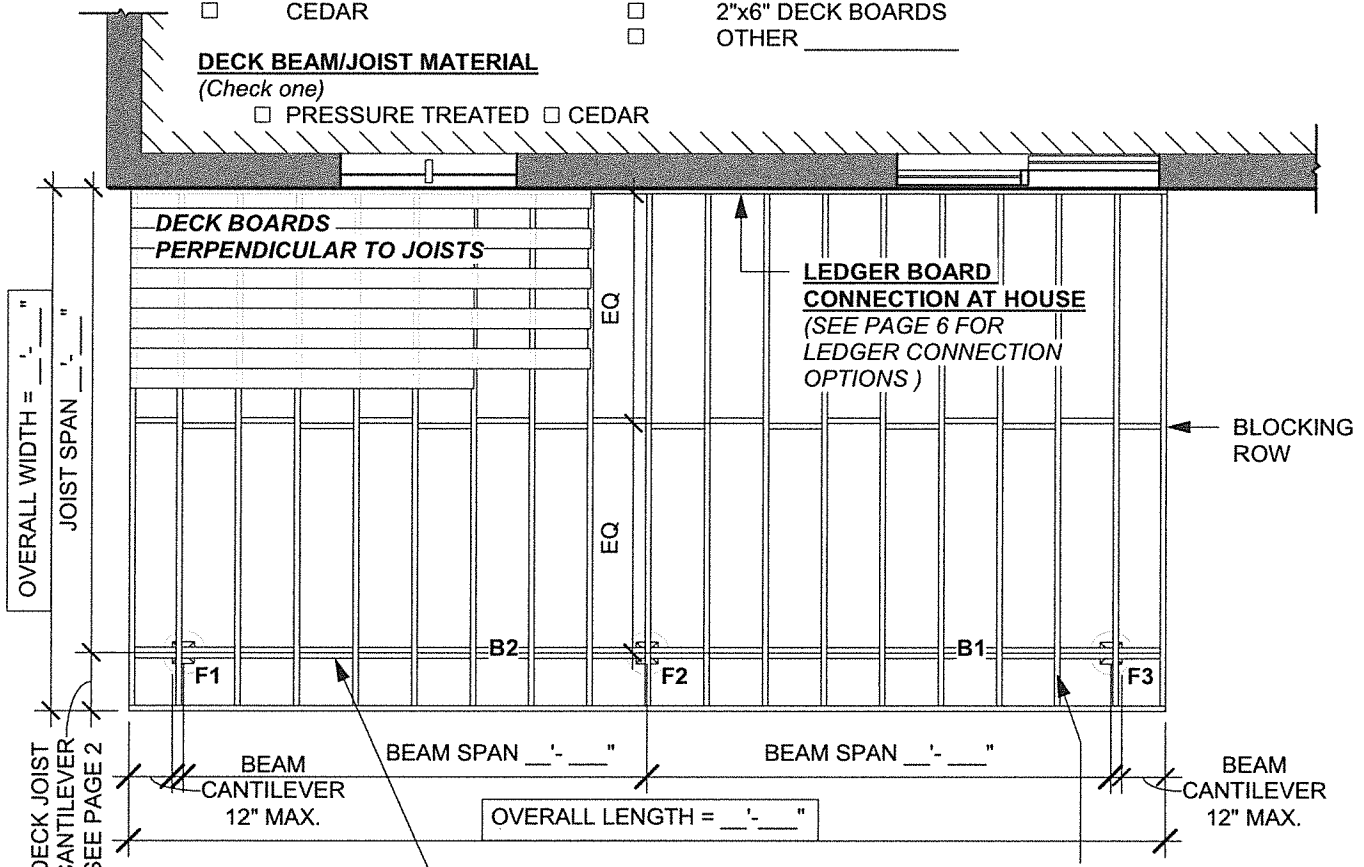

FOOTING SIZE(S)

(Select from Table C on Page 2)

F1: ___" DIAMETER
 F2: ___" DIAMETER
 F3: ___" DIAMETER

DECK BEAM SIZE

(Select from Table B on Page 2)

B1: ___ PLY
 x ___
 B2: ___ PLY
 x ___

DECK JOIST SIZE AND SPACING

(Select from Table A on Page 2)

2 x ___ @ ___" O.C.

DWELLING CONNECTION DETAILS

SEE PAGE 6 FOR FRAMING CONNECTION DETAIL OPTIONS TO DWELLING.

BEAM CONNECTION DETAILS

SEE PAGE 5 FOR FRAMING CONNECTION DETAIL OPTIONS TO BEAMS.

GUARD REQUIRED

WHEN DECK HEIGHT EXCEEDS 24" ABOVE GRADE

BLOCKING ROW

FULL WIDTH OF DECK @ MID SPAN OF DECK JOISTS WHEN CLEAR SPAN EXCEEDS 6'-11".

FOOTING PIER DETAILS

SEE PAGE 4 FOR FOOTING PIER DETAIL OPTIONS TO UNDISTURBED SOIL. EACH FOOTING MAY HAVE A DIFFERENT DIAMETER. PLEASE SPECIFY THE DIAMETER OF EACH FOOTING.

(*PLEASE NOTE, ALL INFORMATION MUST BE FILLED OUT IN ORDER FOR YOUR DECK PLANS TO BE CONSIDERED COMPLETE TO ACCOMPANY YOUR PERMIT APPLICATION TO YOUR LOCAL MUNICIPALITY.)

LOCAL MUNICIPALITY APPROVAL / REVIEW

PRINT NAME (FIRST & LAST)

_____ HAS COMPLETED THIS FORM AND TAKES RESPONSIBILITY FOR THE DESIGN OF THE PROPOSED DECK TO BE LOCATED AT:

ADDRESS _____

SIGNATURE: _____



DECK LAYOUT 2: DOUBLE BEAM OPTION SCALE: 1/4" = 1'-0"

DECK BOARD MATERIAL

(Check one)

- PRESSURE TREATED
 CEDAR

DECK BOARD SIZE

(Check one)

- 5/4" DECK BOARDS (deck joists must be at 16" o/c max)
 2"x6" DECK BOARDS
 OTHER _____

DECK BEAM/JOIST MATERIAL

(Check one)

- PRESSURE TREATED CEDAR

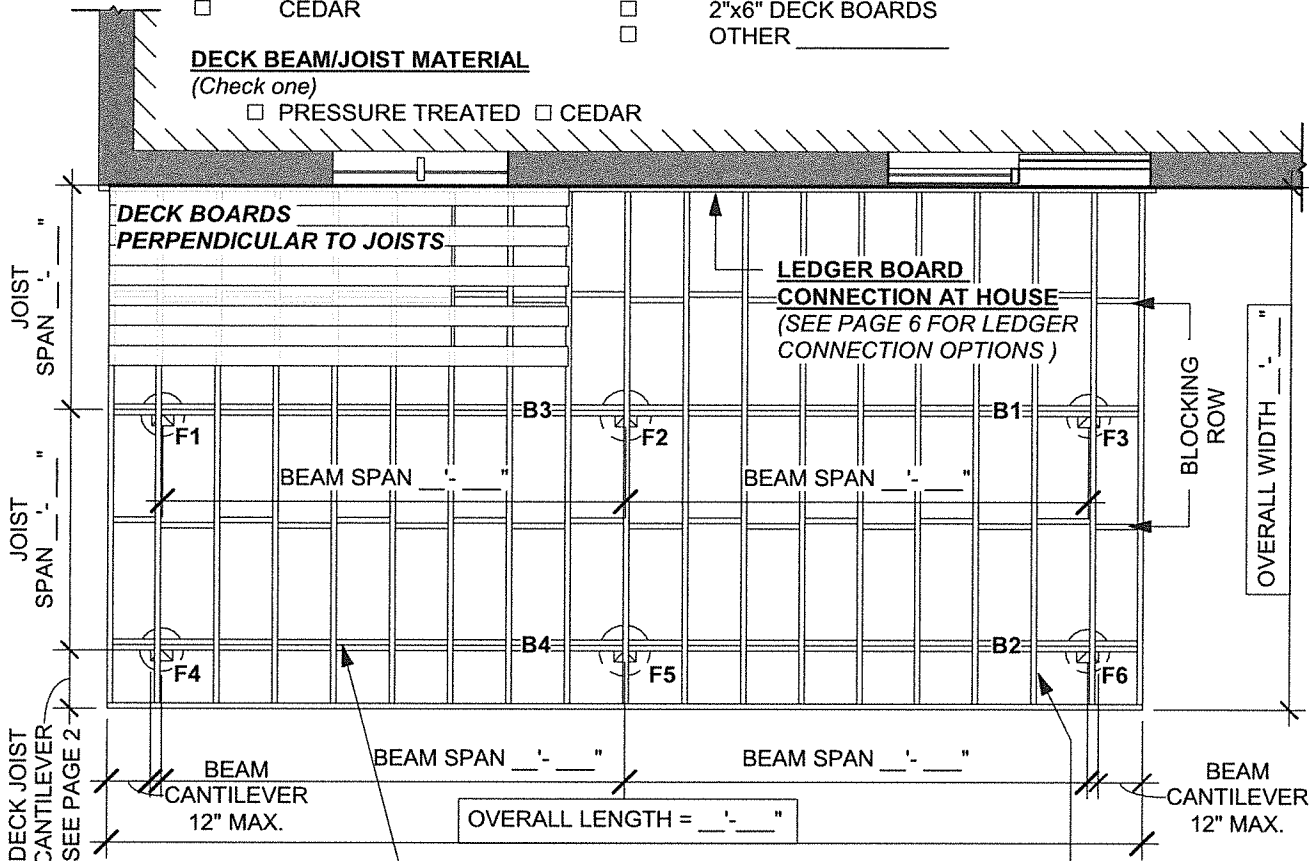

FOOTING SIZE(S)

(Select from Table C on Page 2)

F1: ___" DIAMETER | F2: ___" DIAMETER
 F3: ___" DIAMETER | F4: ___" DIAMETER
 F5: ___" DIAMETER | F6: ___" DIAMETER

DECK BEAM SIZE

(Select from Table B on Page 2)

B1: ___ PLY x ___	B2: ___ PLY x ___
B3: ___ PLY x ___	B4: ___ PLY x ___

DECK JOIST SIZE AND SPACING

(Select from Table A on Page 2)

2 x ___ @ ___" O.C.

GUARD REQUIRED

WHEN DECK HEIGHT EXCEEDS 24" ABOVE GRADE

BLOCKING ROW

FULL WIDTH OF DECK @ MID SPAN OF DECK JOISTS WHEN CLEAR SPAN EXCEEDS 6'-11".

DWELLING CONNECTION DETAILS

SEE PAGE 6 FOR FRAMING CONNECTION DETAIL OPTIONS TO DWELLING.

BEAM CONNECTION DETAILS

SEE PAGE 5 FOR FRAMING CONNECTION DETAIL OPTIONS TO BEAMS.

FOOTING PIER DETAILS

SEE PAGE 4 FOR FOOTING PIER DETAIL OPTIONS TO UNDISTURBED SOIL. EACH FOOTING MAY HAVE A DIFFERENT DIAMETER. PLEASE SPECIFY THE DIAMETER OF EACH FOOTING.

(*PLEASE NOTE, ALL INFORMATION MUST BE FILLED OUT IN ORDER FOR YOUR DECK PLANS TO BE CONSIDERED COMPLETE TO ACCOMPANY YOUR PERMIT APPLICATION TO YOUR LOCAL MUNICIPALITY.)

LOCAL MUNICIPALITY APPROVAL / REVIEW

PRINT NAME (FIRST & LAST)

_____ HAS COMPLETED THIS FORM AND TAKES RESPONSIBILITY FOR THE DESIGN OF THE PROPOSED DECK TO BE LOCATED AT:

ADDRESS _____

SIGNATURE: _____



DECK LAYOUT 3: SINGLE BEAM OPTION - END BEAM TO HOUSE

SCALE: 1/4" = 1'-0"

DECK BOARD MATERIAL

(Check one)

- PRESSURE TREATED
- CEDAR

DECK BOARD SIZE

(Check one)

- 5/4" DECK BOARDS (deck joists must be at 16" o/c max)
- 2"x6" DECK BOARDS
- OTHER _____

DECK BEAM/JOIST MATERIAL

(Check one)

- PRESSURE TREATED
- CEDAR

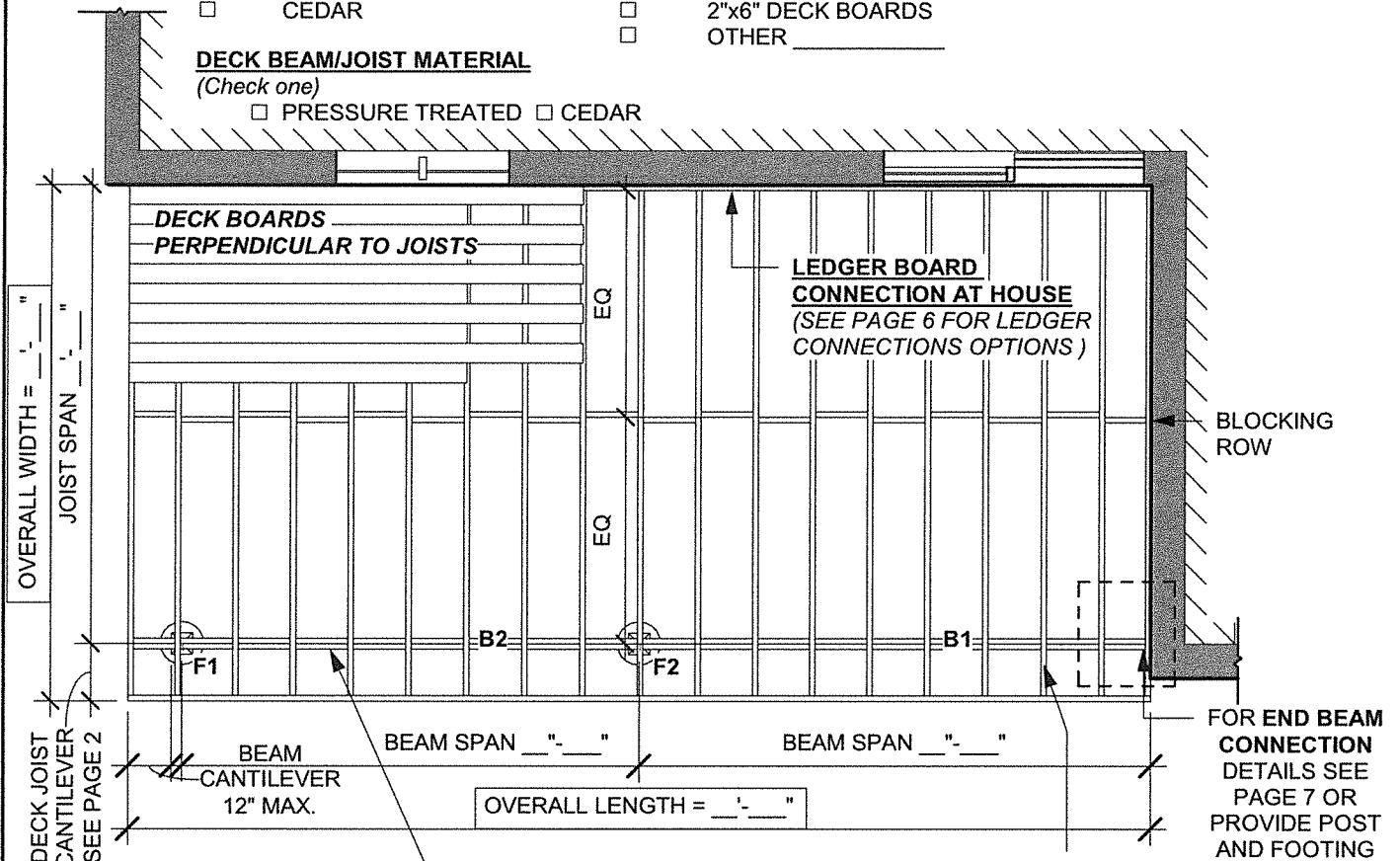

FOOTING SIZE(S)

(Select from Table C on Page 2)

F1: _____" DIAMETER
F2: _____" DIAMETER

DECK BEAM SIZE

(Select from Table B on Page 2)

B1: _____ PLY
x _____
B2: _____ PLY
x _____

DECK JOIST SIZE AND SPACING

(Select from Table A on Page 2)

2 x _____ @ _____" O.C.

GUARD REQUIRED

WHEN DECK HEIGHT EXCEEDS 24" ABOVE GRADE

BLOCKING ROW

FULL WIDTH OF DECK @ MID SPAN OF DECK JOISTS WHEN CLEAR SPAN EXCEEDS 6'-11".

DWELLING CONNECTION DETAILS

SEE PAGE 6 FOR FRAMING CONNECTION DETAIL OPTIONS TO DWELLING.

BEAM CONNECTION DETAILS

SEE PAGE 5 FOR FRAMING CONNECTION DETAIL OPTIONS TO BEAMS.

FOOTING PIER DETAILS

SEE PAGE 4 FOR FOOTING PIER DETAIL OPTIONS TO UNDISTURBED SOIL. EACH FOOTING MAY HAVE A DIFFERENT DIAMETER. PLEASE SPECIFY THE DIAMETER OF EACH FOOTING.

(*PLEASE NOTE, ALL INFORMATION MUST BE FILLED OUT IN ORDER FOR YOUR DECK PLANS TO BE CONSIDERED COMPLETE TO ACCOMPANY YOUR PERMIT APPLICATION TO YOUR LOCAL MUNICIPALITY.)

LOCAL MUNICIPALITY APPROVAL / REVIEW

PRINT NAME (FIRST & LAST)

_____ HAS COMPLETED THIS FORM AND TAKES RESPONSIBILITY FOR THE DESIGN OF THE PROPOSED DECK TO BE LOCATED AT:

ADDRESS _____

SIGNATURE: _____



TABLE A: DECK JOISTS - PER CWC THE SPAN BOOK 2020, TABLE 10.1a.

LUMBER	JOIST SIZE	12" SPACING (O.C.)	16" SPACING (O.C.)	24" SPACING (O.C.)	MAX. JOIST CANTILEVER
SPRUCE - PINE - FIR, NO. 1 & 2	2" x 6"*	10' - 0"	9' - 1"	7' - 11"	NOT PERMITTED
	2" x 8"	13' - 2"	11' - 11"	10' - 1"	LESSER OF 16" OR 1/6 OF TOTAL JOIST LENGTH
	2" x 10"	16' - 10"	15' - 2"	12' - 4"	LESSER OF 24" OR 1/6 OF TOTAL JOIST LENGTH
	2" x 12"	20' - 3"	17' - 7"	14' - 4"	

TABLE 'A' NOTES: 2" x 6" JOIST MAY ONLY BE USED WHERE THE DECK IS LESS THAN 23 1/2" FROM GRADE WHERE NO GUARD IS TO BE PROVIDED. GUARDS REQUIRE MIN. 2" x 8" JOISTS.

TABLE B: DECK BEAMS - PER CWC THE SPAN BOOK 2020, TABLE 10.3a

LUMBER	SUPPORT LENGTH	2" x 8"		2" x 10"		2" x 12"	
		2 - PLY	3 - PLY	2 - PLY	3 - PLY	2 - PLY	3 - PLY
SPRUCE - PINE - FIR, NO. 1 & 2	8'	7' - 2"	8' - 10"	8' - 9"	10' - 9"	10' - 2"	12' - 6"
	10'	6' - 5"	7' - 10"	7' - 10"	9' - 8"	9' - 1"	11' - 2"
	12'	5' - 10"	7' - 2"	7' - 2"	8' - 9"	8' - 4"	10' - 2"
	14'	5' - 5"	6' - 8"	6' - 8"	8' - 2"	7' - 8"	9' - 5"
	16'	5' - 1"	6' - 3"	6' - 2"	7' - 7"	7' - 2"	8' - 10"
	18'	4' - 9"	5' - 10"	5' - 10"	7' - 2"	6' - 9"	8' - 4"
	20'	4' - 6"	5' - 7"	5' - 7"	6' - 10"	6' - 5"	7' - 11"

TABLE 'B' NOTE:
MAX. BEAM CANTILEVER IS 12" FOR ALL SIZES.

TABLES VALID FOR 1.9 kPa (40 psf) OCCUPANCY LIVE LOAD, 0.5 kPa (10 psf) DEAD LOAD AND GROUND SNOW LOADS UP TO 2.7 kPa (56.4 psf).

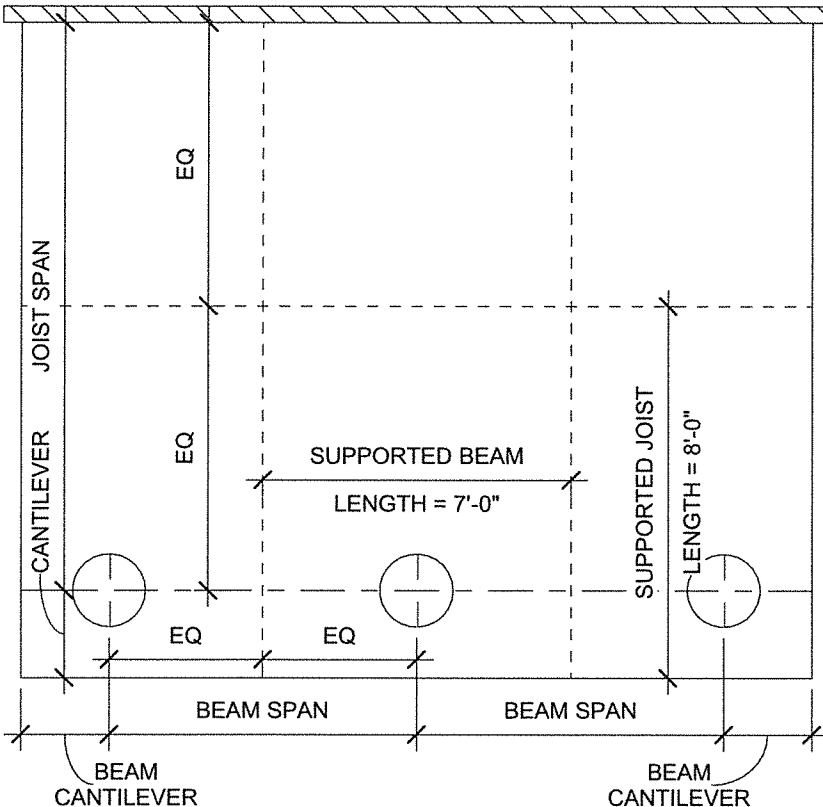

REQUIRED DECK FOOTING CAPACITY

FOOTING LOAD = SUPPORTED BEAM LENGTH x SUPPORTED JOIST LENGTH x 50 LBS/SQFT (DECK LOADS, SEE O.B.C. 9.4.2.3.)

USE FOOTING/PIER SIZING TABLE BELOW TO DETERMINE MINIMUM FOOTING SIZE BASED ON FOOTING LOAD.

EXAMPLE (MIDDLE FOOTING):

- SUPPORT BEAM LENGTH = 7'-0"
 - SUPPORT JOIST LENGTH = 8'-0"
 - FOOTING LOAD = 7 x 8 x 50 = 2240 LBS
- THEREFORE, MIDDLE FOOTING WOULD REQUIRE 16" DIA. OR 14" SQUARE FOOTING.

TABLE C: FOOTING / PIER SIZING TABLE

MINIMUM FOOTING SIZE	MAX. FOOTING CAPACITY	
	ROUND (DIA.)	SQUARE
10"	1139 LBS	1450 LBS
12"	1640 LBS	2089 LBS
14"	2233 LBS	2843 LBS
16"	2916 LBS	3713 LBS
18"	3691 LBS	4699 LBS
24"	6560 LBS	8352 LBS

NOTE: MAX. FOOTING CAPACITY BASED ON A SOIL BEARING CAPACITY OF 100 kPa (2088 psf)

2 TABLES AND CALCULATIONS
1/4" = 1'-0"



PLEASE CHECK ONE OF THESE APPROVED DETAILS FOR DESIGN OF CONNECTION FOR POST TO FOOTING

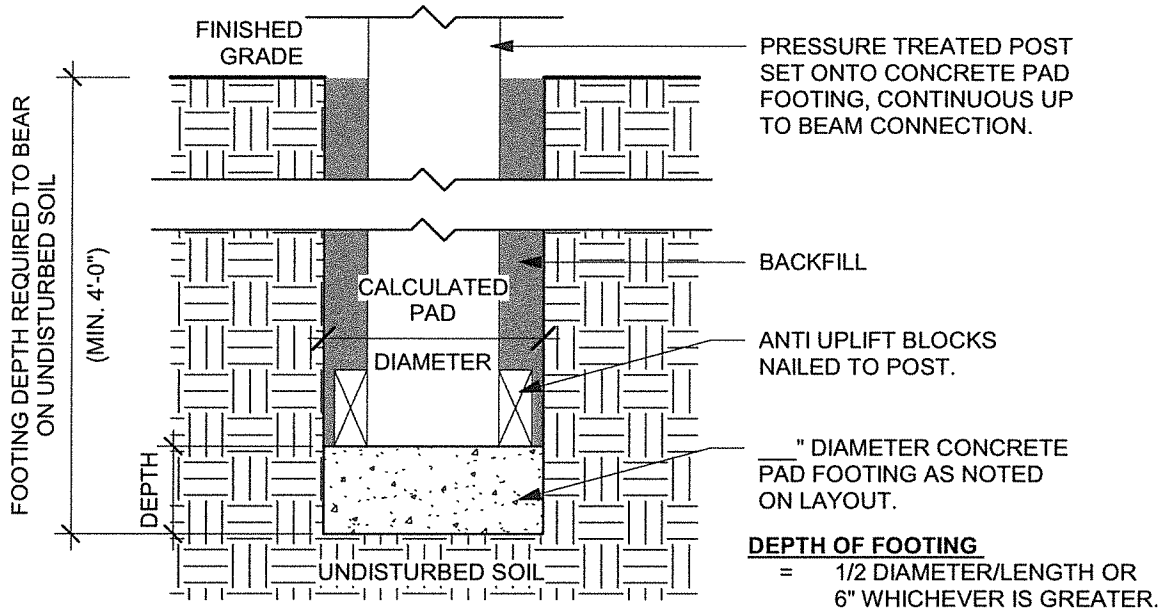

DETAIL 3a - POST TO CONCRETE PAD FOOTING

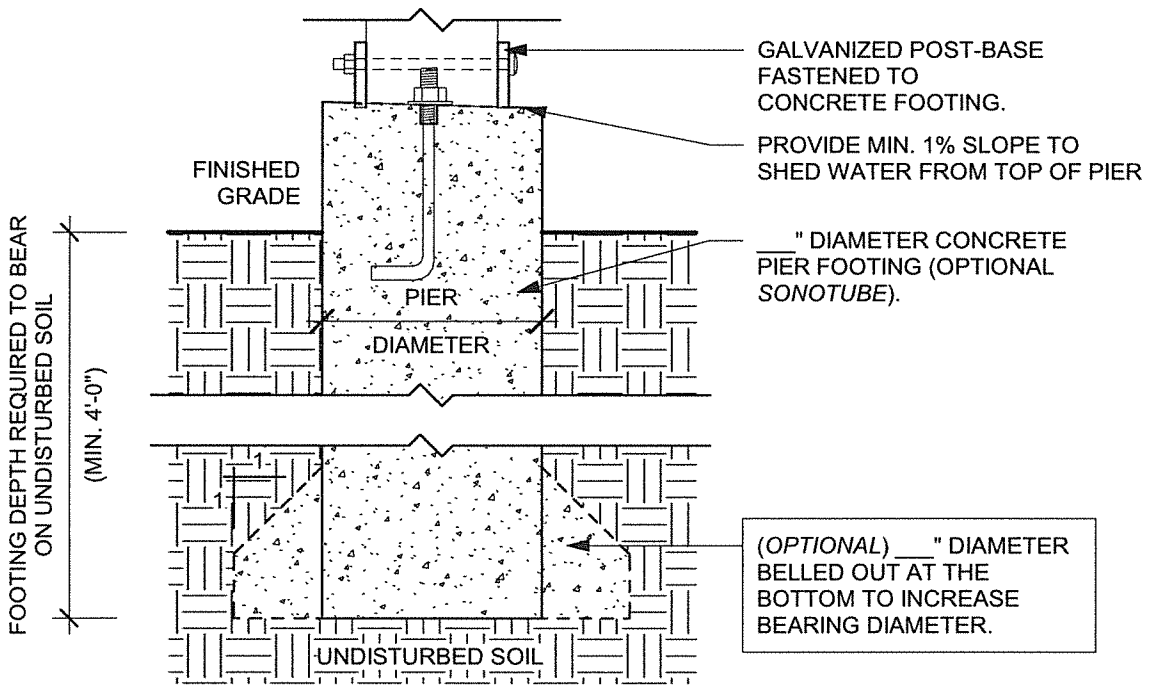

DETAIL 3b - POST BASE SET INTO CONCRETE PIER

4 FOUNDATION CONNECTIONS
1 1/2" = 1'-0"



PROVIDE BRACKET AS PER MANUFACTURERS RECOMMENDATIONS

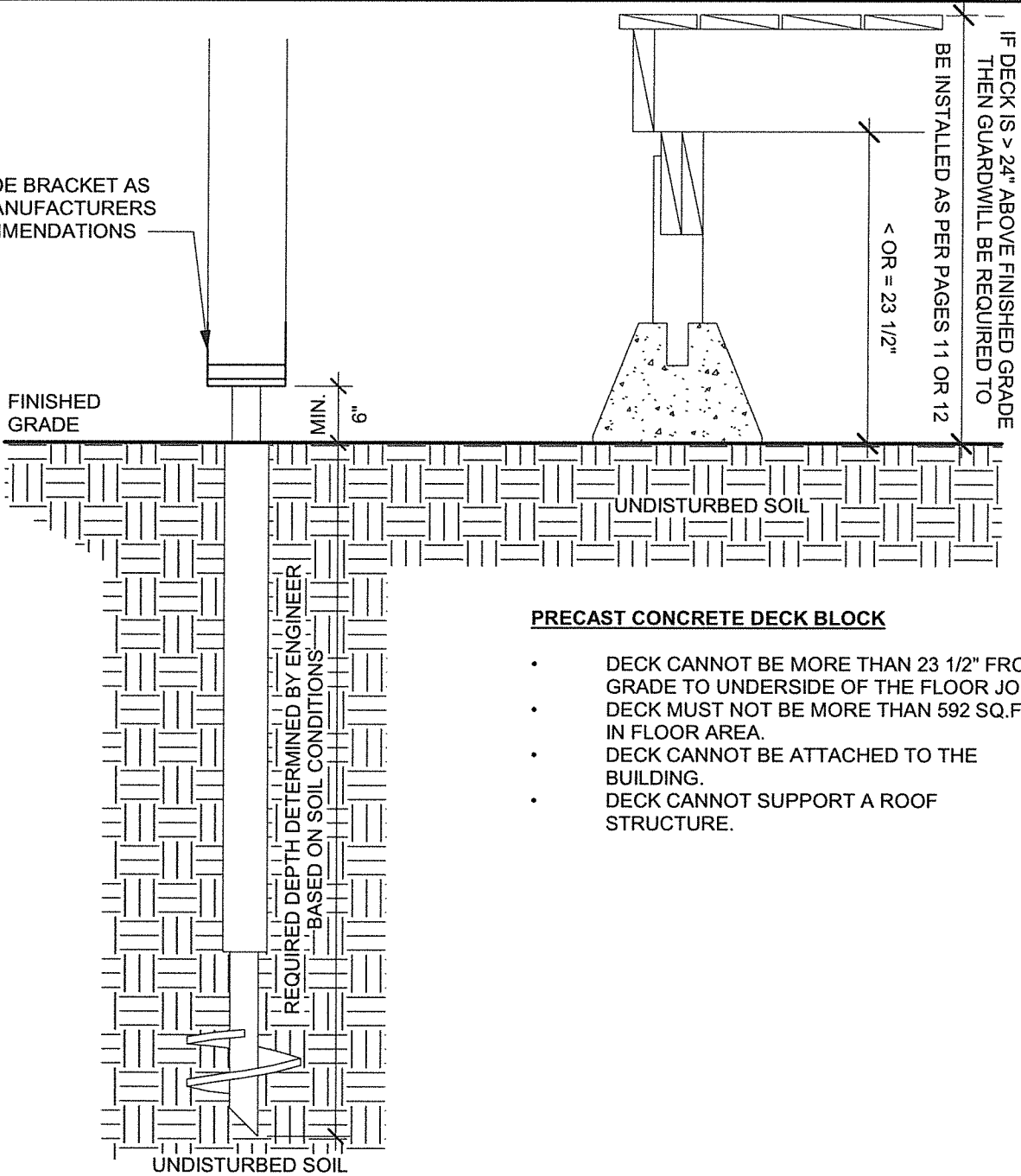

PRECAST CONCRETE DECK BLOCK

- DECK CANNOT BE MORE THAN 23 1/2" FROM GRADE TO UNDERSIDE OF THE FLOOR JOIST.
- DECK MUST NOT BE MORE THAN 592 SQ.FT. IN FLOOR AREA.
- DECK CANNOT BE ATTACHED TO THE BUILDING.
- DECK CANNOT SUPPORT A ROOF STRUCTURE.

STEEL HELICAL PILE/PIER

- MANUFACTURER' INFORMATION MUST BE SUBMITTED WITH PERMIT APPLICATION ALONG WITH CCMC APPROVAL
- PROFESSIONAL ENGINEER MUST DETERMINE THE DEPTH, SPACING AND SIZE OF HELICALS BASED ON SOIL CONDITION

USE OF DECK BLOCKS AND/OR STEEL HELICAL PILES IS SUBJECT TO MUNICIPAL APPROVAL. CONTACT YOUR LOCAL BUILDING DEPARTMENT TO DISCUSS USE OF THESE OPTIONS.

FOUNDATION CONNECTIONS - HELICAL PILE/DECK BLOCK

4a 1 1/2" = 1'-0"



PLEASE CHECK ONE OF THESE APPROVED DETAILS FOR DESIGN OF CONNECTION FOR POST TO BEAM

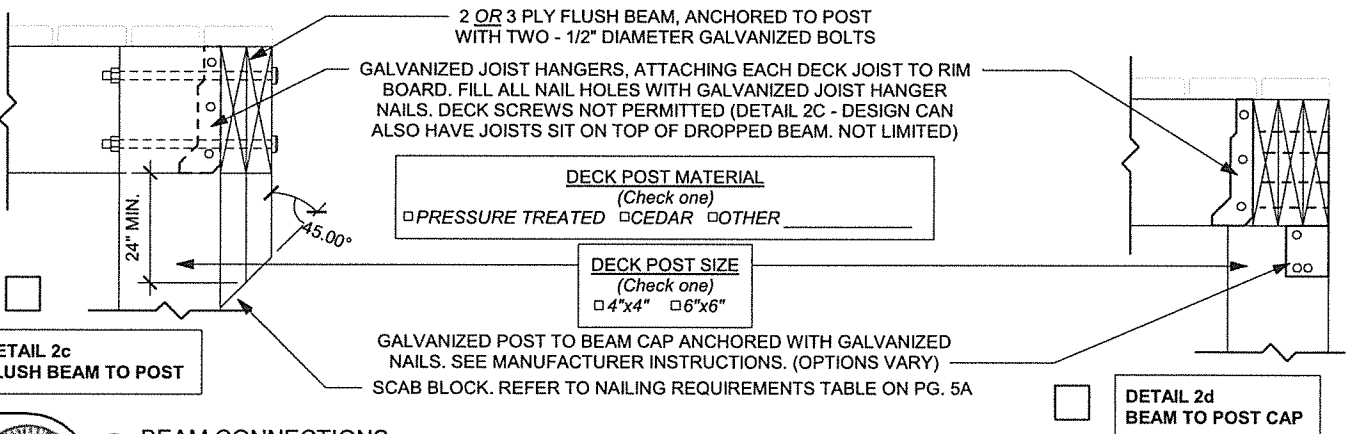
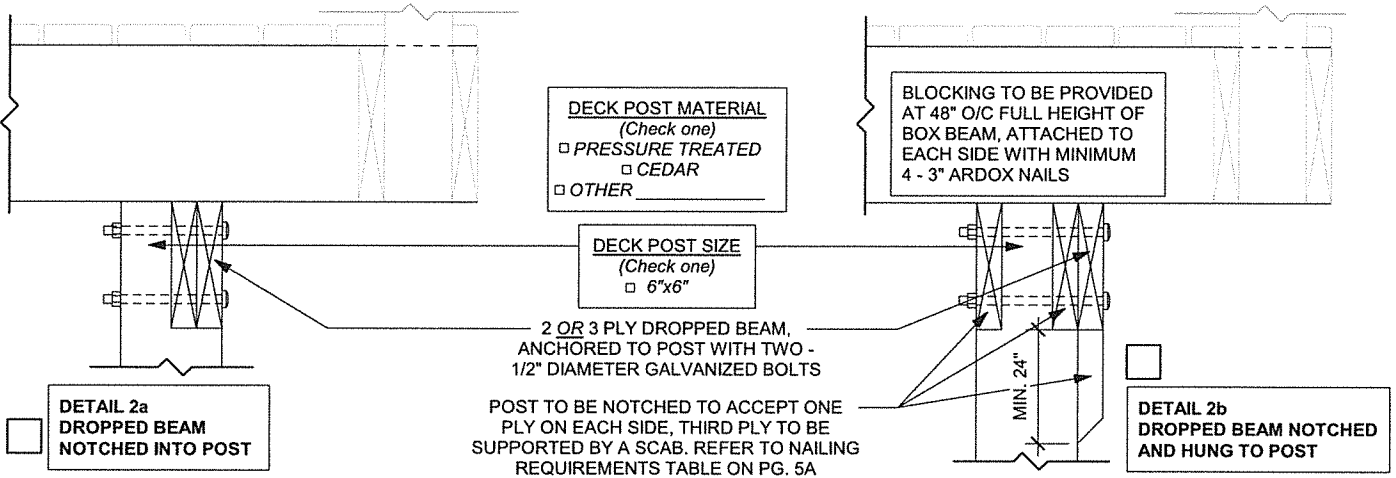

5 BEAM CONNECTIONS
1 1/2" = 1'-0"

PLEASE CHECK ONE OF THESE APPROVED DETAILS FOR DESIGN OF CONNECTION FOR POST TO BEAM

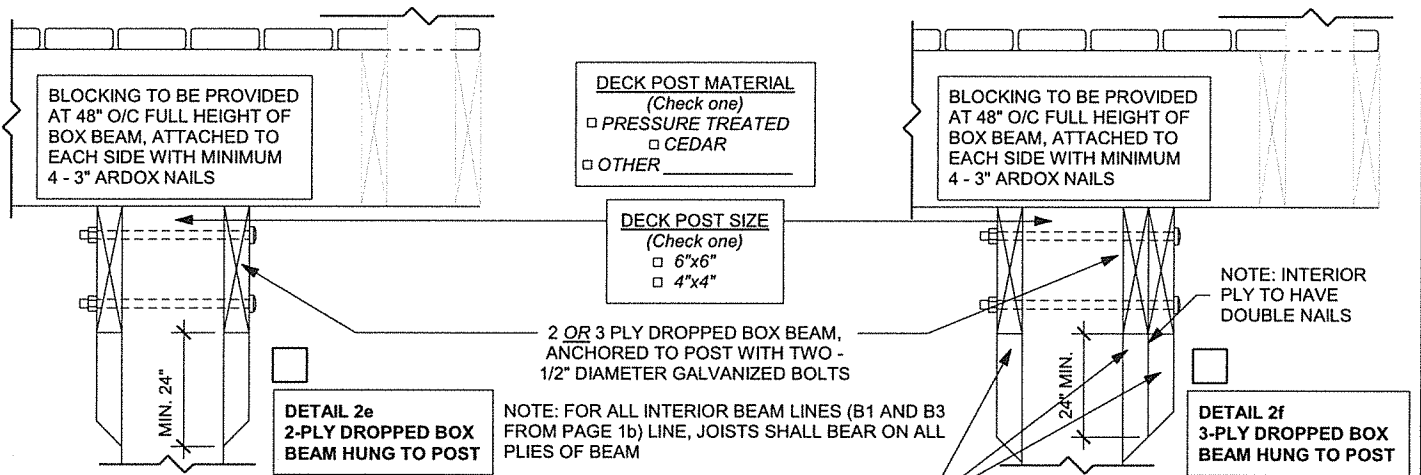

TABLE D: NAIL REQUIREMENTS

FOOTING POUNDS	3" NAILS		3 1/2" NAILS	
	2 PLY	3 PLY	2 PLY	3 PLY
2000	13	9	9	6
3000	19	13	13	9
4000	25	17	17	12
5000	32	21	21	14
7000	44	30	30	20
8500	54	36	36	24

ALL PLYS TO BE SUPPORTED BY A FULL POST WIDTH SCAB. REFER TO NAILING REQUIREMENTS TABLE ON PG. 5A.

HOW TO USE TABLE D:

1. SELECT SIZE OF NAILS.
2. SELECT NUMBER OF PLYS IN BEAM.
3. BASED ON THE FOOTING LOAD (REFER TO TABLE C ON PAGE 2) SELECT NUMBER OF NAILS REQUIRED IN EACH SCAB BLOCK.
4. FOR 3 PLY BEAMS ONLY - REMEMBER THE INTERIOR SCAB BLOCK NEEDS TWICE THE NUMBER OF NAILS.
5. USING THE NAIL SPACING, DETERMINE THE MINIMUM SCAB BLOCK SIZE.

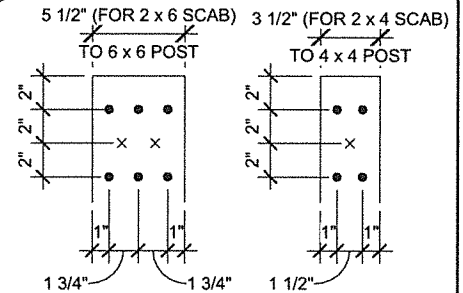

TYPICAL MINIMUM NAIL SPACING
 ADD ROWS OF NAILS AS REQUIRED TO MEET NAILING REQUIREMENTS OF TABLE

5a **BEAM CONNECTIONS - CONTINUED**
 1 1/2" = 1'-0"



FLOOR ASSEMBLY
- SUBFLOOR
- FLOOR JOISTS
ATTACHED TO RIM
BOARD

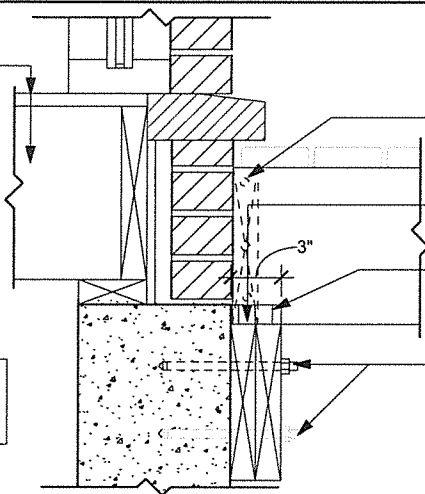

2/3rds JOIST DEPTH BLOCKING BETWEEN JOISTS TO PREVENT TWISTING. FRICTION FIT INTO PLACE AND FASTEN TO JOISTS ON BOTH SIDES. DO NOT COVER THE BRICK WEEP HOLES.

FASTEN FLOOR JOISTS TO THE LEDGER BOARD WITH A 3" GALVANIZED NAIL, EACH SIDE.

MINIMUM 1.5" BEARING FOR JOISTS

ATTACH MINIMUM 2 PLY LEDGER BOARD TO FOUNDATION WALL WITH 1/2" DIAMETER GALVANIZED EXPANSION ANCHORS WITH MINIMUM 4" EMBEDMENT IN CONCRETE FOUNDATION, STAGGERED SPACING MATCHED TO JOIST SPACING (i.e. JOISTS AT 16" O.C., ANCHORS AT 16" O.C.). PRE-DRILL HOLES, SEE MANUFACTURER DETAILS FOR INSTALL.

DETAIL 1a - BRICK - DROPPED LEDGER BOARD TO FOUNDATION WALL

FLOOR ASSEMBLY
- SUBFLOOR
- FLOOR JOISTS
ATTACHED TO RIM
BOARD

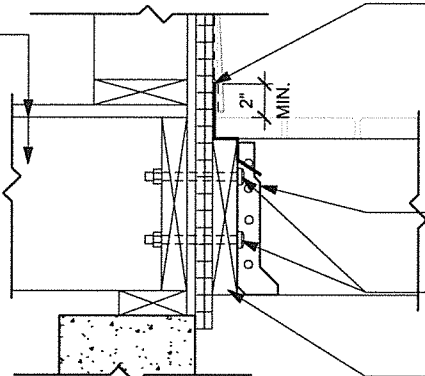

FLASHING REQUIREMENTS

- EXTEND 2" VERTICALLY ABOVE DECK, UNDER THE MEMBRANE OR SHEATHING.
- MUST BE BENT TO HAVE SLOPE OUTWARD, TO SHED WATER AT BOTTOM.
- TERMINATE AT EACH END HORIZONTALLY WITH AN END-DAM.
- MUST LAP 1/2" OVER THE BUILDING ELEMENT BELOW, AND TERMINATE IN A DRIP EDGE (BEND AT BOTTOM) 1/4" AWAY FROM LOWER BUILDING ELEMENT

GALVANIZED JOIST HANGERS. FILL ALL NAIL HOLES WITH GALVANIZED JOIST HANGER NAILS. DECK SCREWS NOT PERMITTED.

BOLT LEDGER BOARD THROUGH INTERIOR RIM BOARD WITH TWO - 1/2" DIAMETER GALVANIZED BOLTS, SPACING MATCHED TO JOISTS

SINGLE LEDGER BOARD FOR 1.5" 10d NAILS ON HANGERS, EQUAL DEPTH OF DECK JOISTS.

NOTE: IF INTERIOR HAS A DOUBLE RIM JOIST (76 mm MIN. THICKNESS) 1/2" DIA. LAG SCREWS WITH FULL PENETRATION MAY BE USED IN LIEU OF BOLTS

DETAIL 1b - SIDING - LEDGER BOARD TO RIM BOARD

6 LEDGER BOARD CONNECTIONS
1 1/2" = 1'-0"

PLEASE CHECK ONE OF THESE APPROVED DETAILS FOR DESIGN OF CONNECTION FOR LEDGER BOARD

NO CONNECTIONS ALLOWED THROUGH BRICK. BRICK IS NOT STRUCTURAL



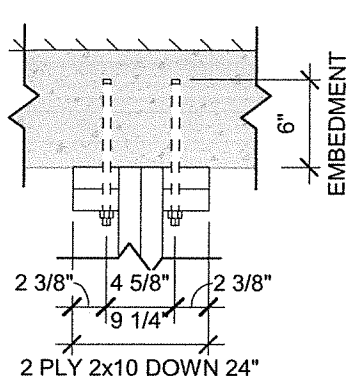

PLAN VIEW

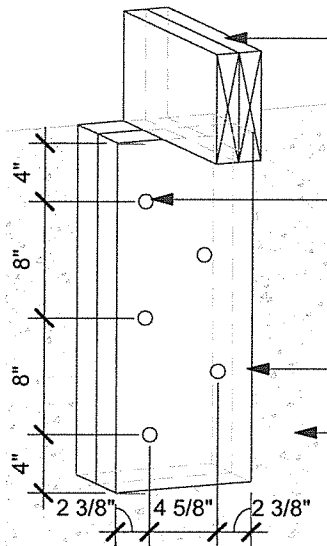

3D VIEW

PRESSURE TREATED (P.T.) BEAM, TOE SCREWED TO BEAM SUPPORT, 2 SCREWS PER MEMBER (IF USING SPLIT BEAM THEN ADD SOLID BLOCKING BETWEEN MEMBER AGAINST THE WALL AND AT EVERY 24")

(5) 5/8" DIA. A307 ANCHORS (LOCATED AS SHOWN). PRE-DRILL 3/4" HOLES INTO FOUNDATION WITH 6" EMBEDMENT & EPOXY IN PLACE WITH HILTI HIT-HY200 ADHESIVE (OR EQUAL)

2 PLY P.T. 2x10 (24" LONG EACH)

FOUNDATION WALL

DETAIL 4a
END BEAM SUPPORT DETAIL - OPTION 1

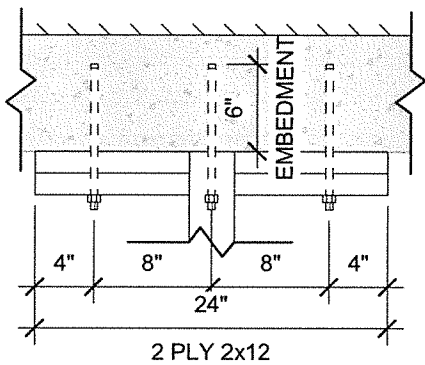

PLAN VIEW

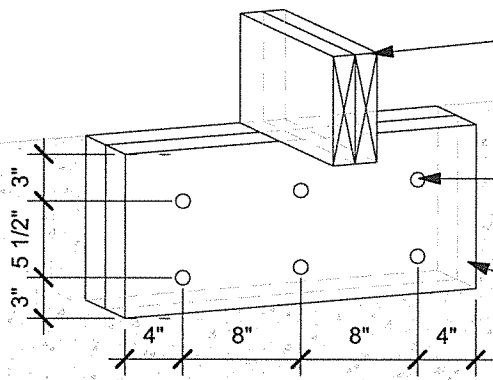

3D VIEW

PRESSURE TREATED (P.T.) BEAM, TOE SCREWED TO BEAM SUPPORT, 2 SCREWS PER MEMBER (IF USING SPLIT BEAM THEN ADD SOLID BLOCKING BETWEEN MEMBER AGAINST THE WALL AND AT EVERY 24")

(6) 5/8" DIA. A307 ANCHORS (LOCATED AS SHOWN). PRE-DRILL 3/4" HOLES INTO FOUNDATION WITH 6" EMBEDMENT & EPOXY IN PLACE WITH HILTI HIT-HY200 ADHESIVE (OR EQUAL)

2 PLY P.T. 2x12 (24" LONG EACH)

FOUNDATION WALL

DETAIL 4b
END BEAM SUPPORT DETAIL - OPTION 2

7 END BEAM CONNECTION AT DWELLING
1" = 1'-0"



GUARD POST SIZE

(Check one)

- 4"x4"
- OTHER _____

GUARD POST MATERIAL

(Check one)

- PRESSURE TREATED
- CEDAR
- OTHER _____

GUARD PICKET SIZE

(Check one)

- 2"x2"
- OTHER _____

GUARD PICKET MATERIAL

(Check one)

- PRESSURE TREATED
- CEDAR
- OTHER _____

***GUARDS AND CONNECTION DETAILS MUST CONFORM TO SB-7 OF THE O.B.C.
 FOR PREFABRICATED GUARD SYSTEMS, PROVIDE ENGINEERING FOR GUARD
 SYSTEM AND GLASS (IF APPLICABLE) FROM THE MANUFACTURER.***

SEE PAGE 9 & 10 FOR GUARD CONSTRUCTION OPTIONS

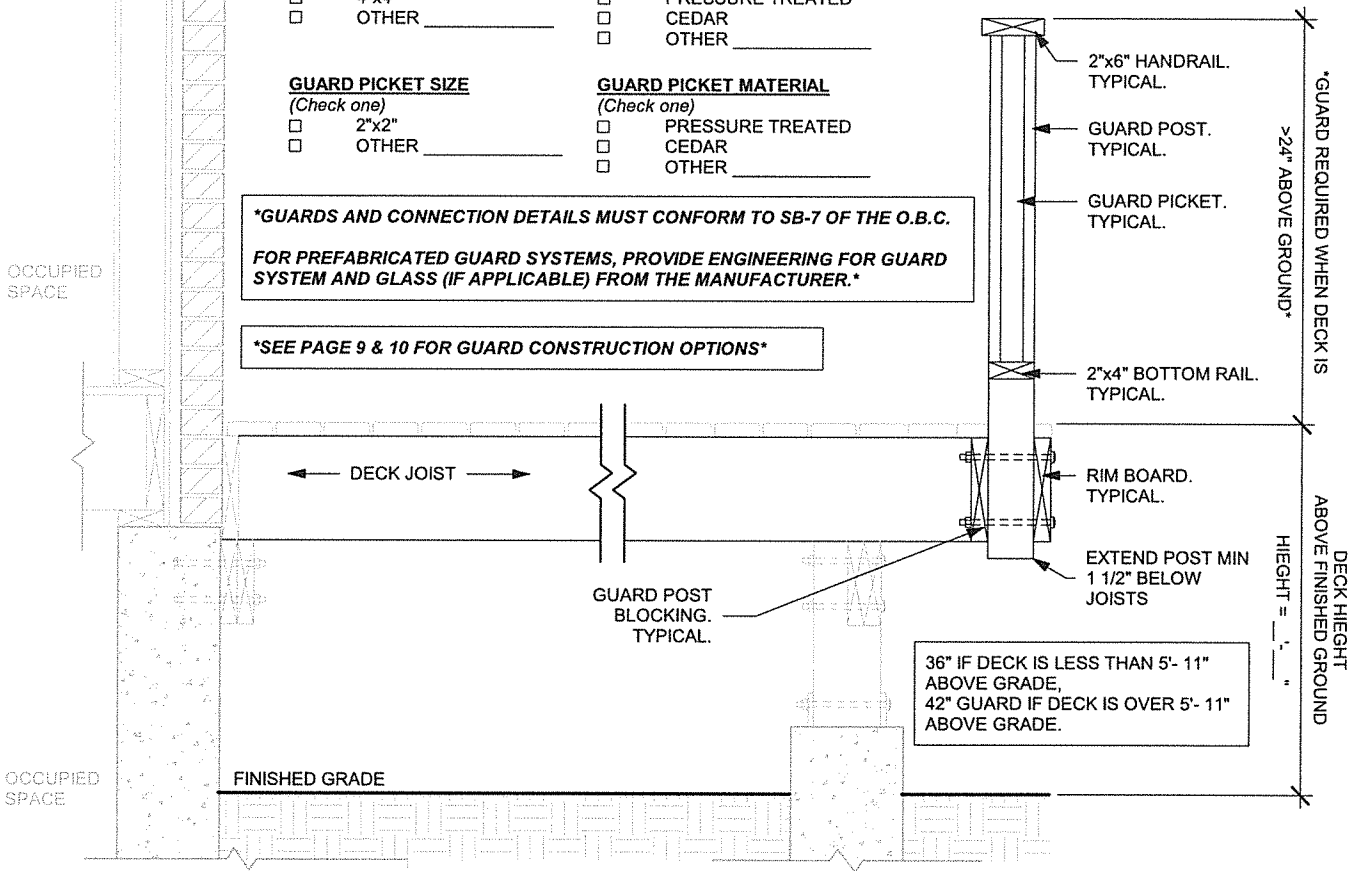

8 DECK SECTION - GUARDRAIL
 1" = 1'-0"

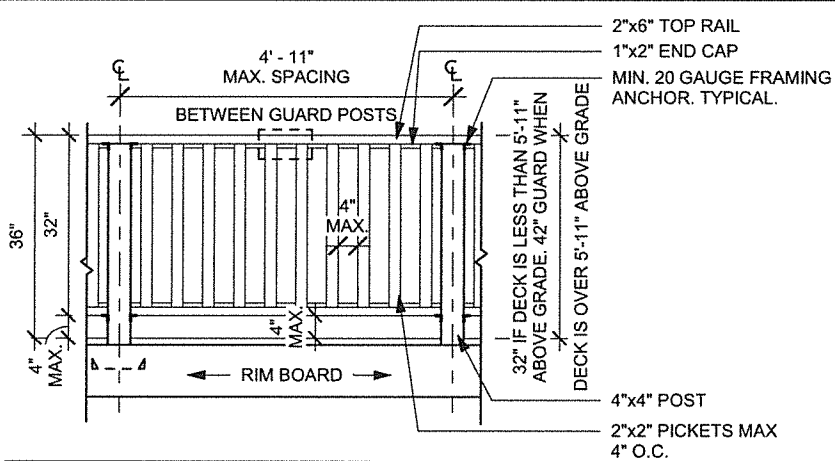

GUARD ELEVATION (SB-7 DETAIL EA-5)

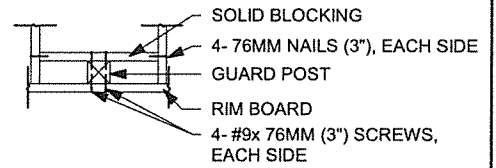

DETAIL (SB-7 DETAIL EB-2)
GUARD POST ATTACHMENT, TYPICAL

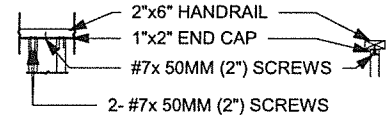

DETAILS (SB-7 DETAIL EC-1)
END CAP AND PICKET ATTACHMENT, TYPICAL

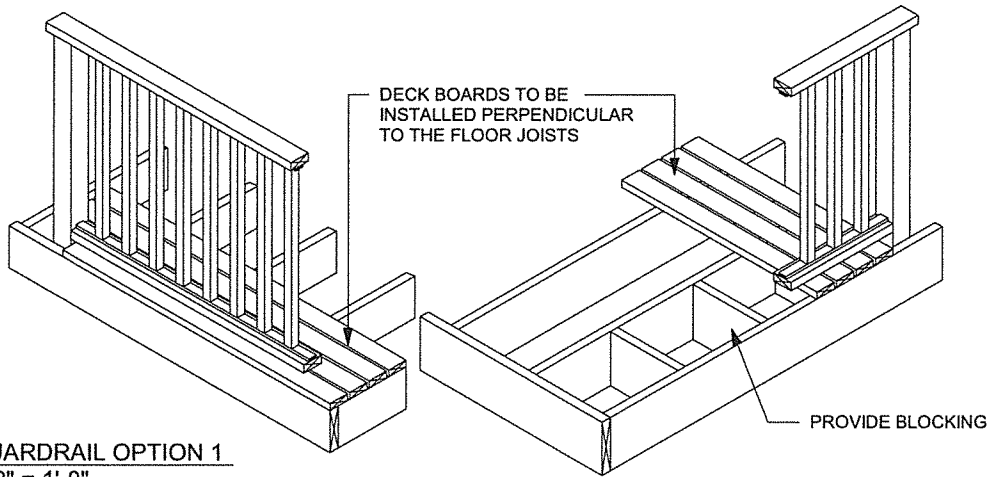

9 GUARDRAIL OPTION 1
1/2" = 1'-0"

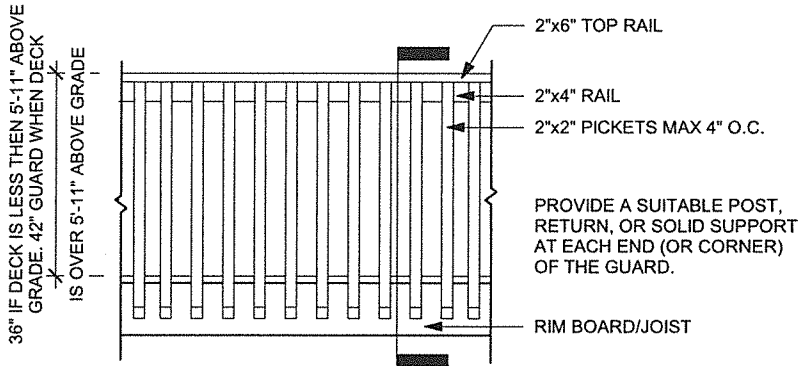

GUARD ELEVATION
(SB-7 DETAIL ED-1/ED-2)

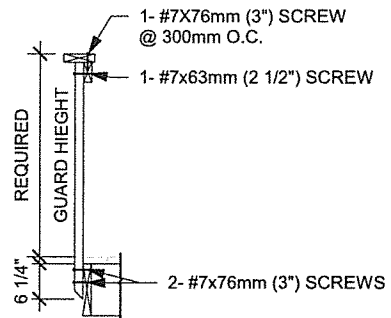

DETAIL (SB-7 DETAIL ED-1/ED-2)
PICKET ATTACHMENT, TYPICAL

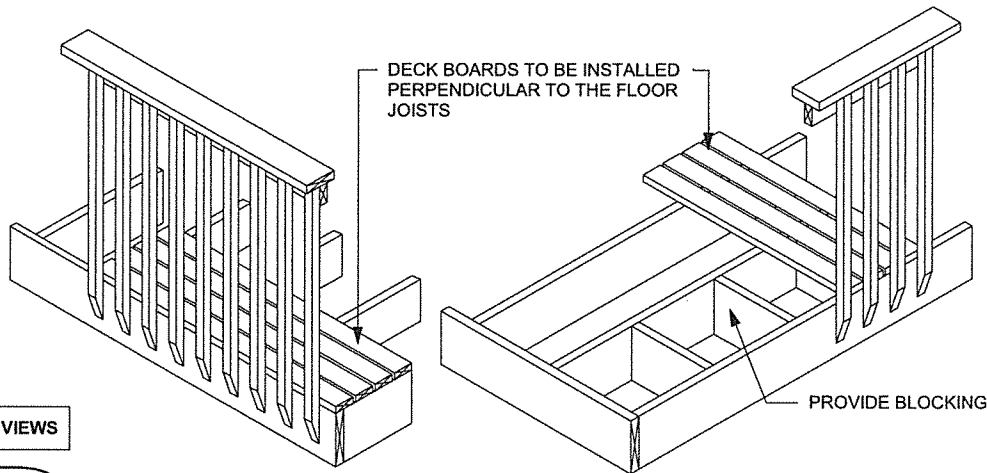

3D VIEWS

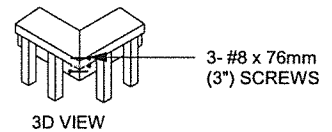

3D VIEW

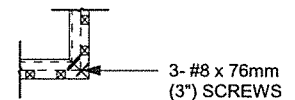

PLAN VIEW

CORNER CONNECTION NOTE: ONE FASTENER IN HORIZONTALLY ORIENTED PORTION OF TOP RAIL AND TWO IN VERTICALLY ORIENTED PORTION.

DETAIL (SB-7 DETAIL ED-5)
CORNER JOIN, TYPICAL



10 GUARDRAIL OPTION 2
1/2" = 1'-0"

GUARDS CONSTRUCTED PER SB-7 OF THE O.B.C.

36" STAIR GUARD REQUIRED ON STAIRS WITH FINISHED DECK HEIGHT OF 24" OR HIGHER.

STAIR HANDRAIL REQUIRED ON STAIRS WITH 3 OR MORE RISERS. (HEIGHT 34" MIN. - 42" MAX.)

STRINGERS MUST BE SUPPORTED AND SECURED AT THE TOP AND BOTTOM (MAX. SPACING 35 1/2"). MID-POINT SUPPORT IS NEEDED WHEN STRINGERS ARE CUT TO ACCEPT TREADS AND ARE GREATER THAN 6'-0" IN LENGTH

WOODEN STRINGERS TO BE TREATED FOR GROUND CONTACT

STAIR CONFIGURATIONS

RISE: MAX= 7 7/8", MIN= 5"
 RUN: MAX= 14", MIN= 10 1/16"
 WIDTH: MIN= 34" (MEASURED BETWEEN INTERIOR FACES OF GUARDS)

2X2 PICKETS ATTACHED WITH TWO SCREWS AT TOP AND BOTTOM. SPACED SO GAPS BETWEEN PICKETS ARE A MAXIMUM OF 4".

MINIMUM 4x4 POST REQUIRED AT TOP AND BOTTOM OF STAIR GUARD. PROVIDE ADEQUATE BLOCKING TO PREVENT LATERAL MOVEMENT.

MAXIMUM GAP IN RISER SO NO OBJECTS LARGER THAN 4" CAN FIT THROUGH OPENING

MAXIMUM NOSING FOR ALL TREADS INCLUDING TOP AND BOTTOM

WHEN 5/4" TREADS ARE BEING USED THE STRINGERS MUST NOT BE SPACED MORE THAN 16" ON CENTRE.

POURED CONCRETE PAD OR CONCRETE PAVERS
 SOLID COMPACTED CHIPS AND DUST

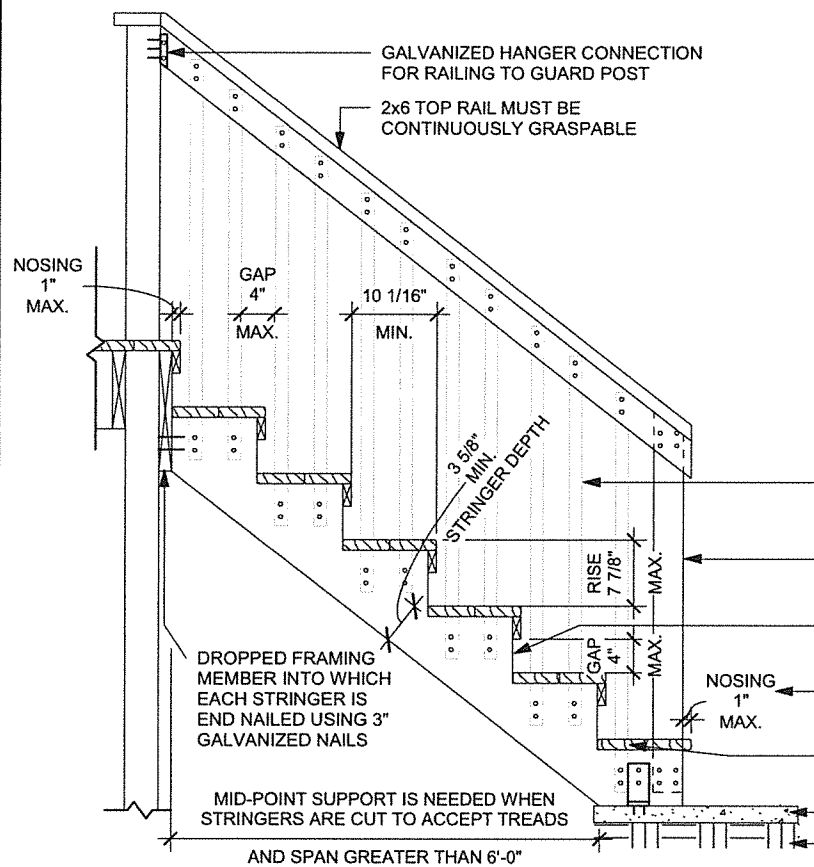

11 Stair Section
 3/4" = 1'-0"

